

# Key Stage 2

## Mathematics

### Paper 3: Reasoning

First Name						
Middle Name						
Last Name						
Date of Birth	Day		Month		Year	
School Name						

Published November 2020

**Please note:**

The following test uses questions from Paper 3, the 2<sup>nd</sup> reasoning paper, from the 2019 SATs.

The questions have been organised from Year 3 content to Year 6 content and additional pages have been inserted to divide the paper up into sections in case teachers wish to administer the test in smaller sections and build pupil's confidence over a period of time.

Questions that require knowledge from different year groups have been placed within the section for the older year group content.



# Year 3

1.

Write the missing digits to make this **addition** correct.

$$\boxed{\phantom{0}} \boxed{2} \boxed{\phantom{0}} + \boxed{\phantom{0}} \boxed{2} = 200$$

---

1 mark

2.

How many days are there in September, October and November altogether?

**days**

---

1 mark

# Year 4

3.

The **original** price of this car is £8,999

**Sale**  
**£1,100 off**

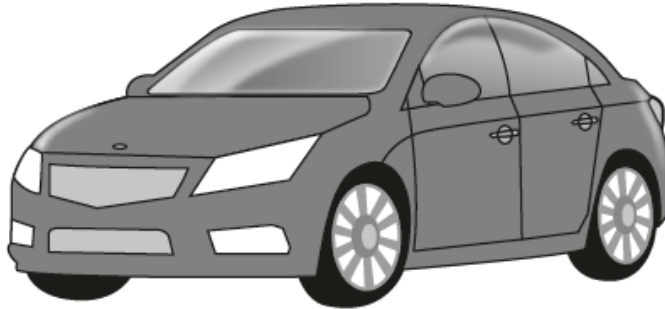

What is the **sale** price of the car?

£

---

1 mark





5.

This picture shows the masses of eight kittens.



305 g



375 g



310 g



255 g



275 g



410 g



360 g



345 g

What is the **difference** in mass between the heaviest kitten and the lightest kitten?

 g

---

1 mark

6.

Ken is playing a game. He has 4,289 points.

Then he scores another 355 points.

Ken's target is 6,000 points.

How many **more** points does Ken need to reach his target?

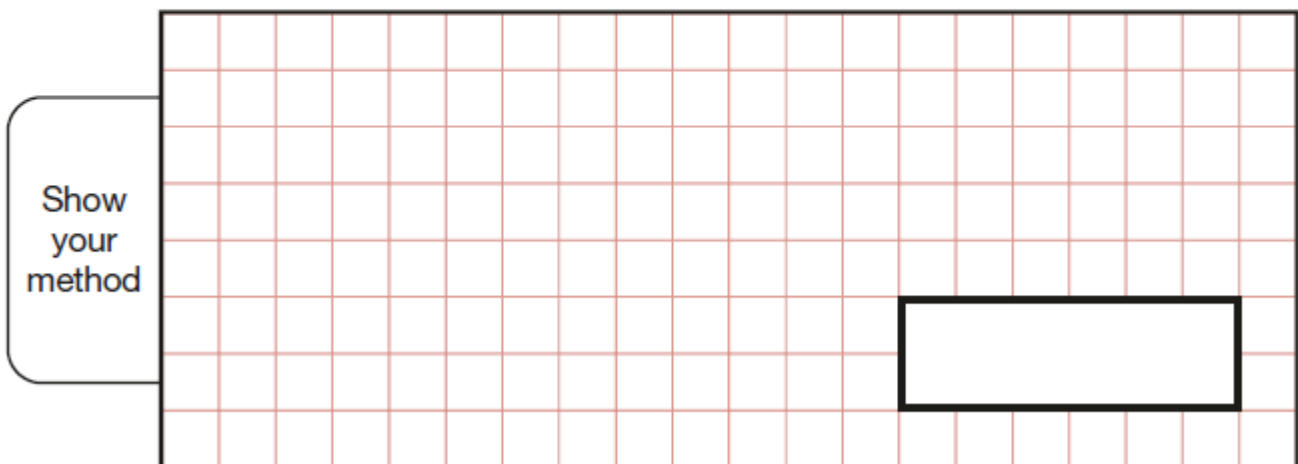

2 marks

7.

This pictogram shows the number of satellites above the Earth in 2016.

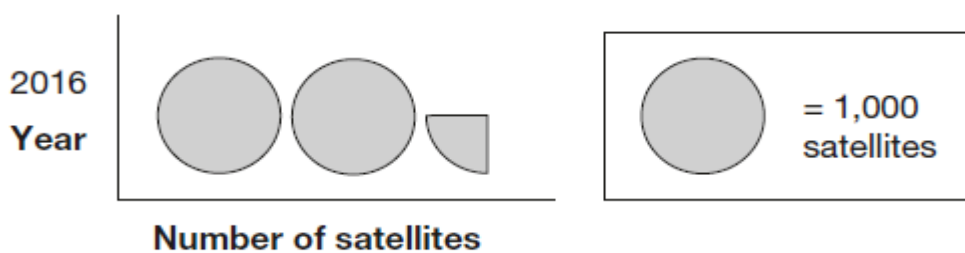

How many satellites were above the Earth in 2016?

1 mark

8.



Kirsty says,

When you double the size of an acute angle,  
you always get an obtuse angle.

Explain why Kirsty is **not** correct.

A large, empty, cloud-shaped box with a scalloped border, intended for the student to write their explanation.

---

1 mark

# Year 5

9.

Write these masses in order, starting with the **lightest**.

1.25 kg

0.99 kg

1.025 kg

0.009 kg

kg

kg

kg

kg

lightest

---

1 mark

10.

This picture shows the masses of eight kittens.

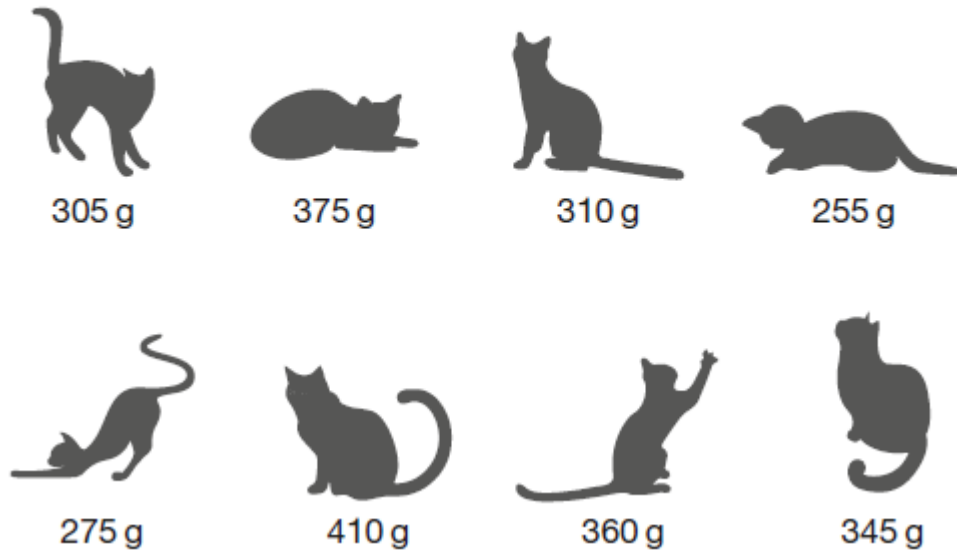

The masses of the kittens are to be put in four groups.

Write the missing numbers in the table.

One has been done for you.

Mass in g	Number of kittens
250–299	
300–349	
350–399	
400–449	1

---

1 mark



12.

Tick the fractions less than  $\frac{5}{8}$

$$\frac{1}{2} \quad \square$$

$$\frac{2}{8} \quad \square$$

$$\frac{3}{4} \quad \square$$

$$\frac{7}{16} \quad \square$$

$$\frac{24}{32} \quad \square$$

---

2 marks



13.

**ABDE** is a rectangle on coordinate axes.

The sides of the rectangle are parallel to the axes.

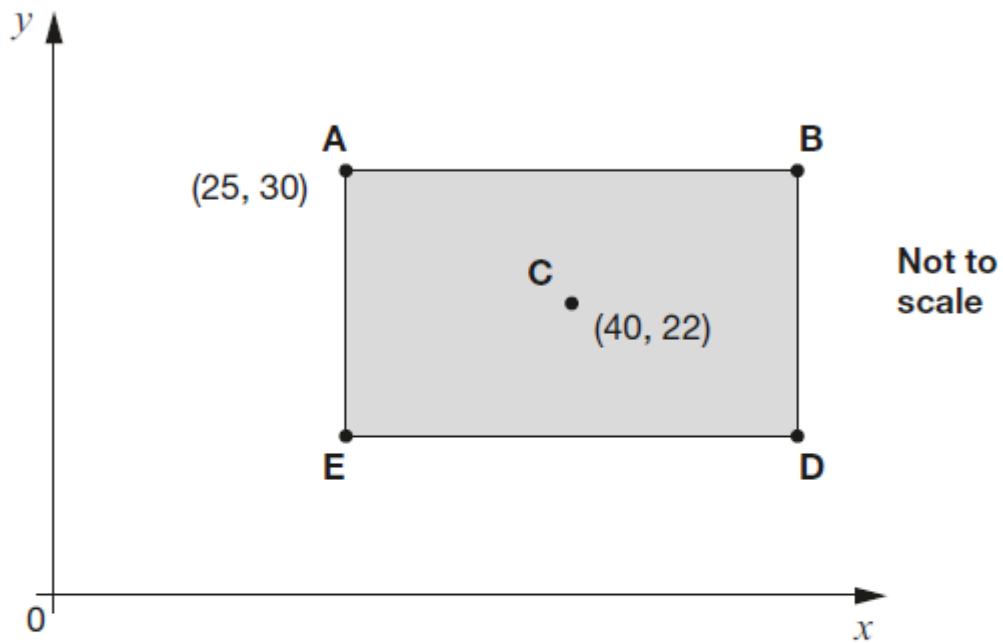

Point **C** is the centre of the rectangle.

What are the coordinates of **B** and **D**?

**B** is

**D** is

---

2 marks

# Year 6

14.

3,576,219

Which digit is in the **ten thousands** place?

Round 3,576,219 to the **nearest million**.

---

2 marks

15.

Dev says,

I had £10  
I gave some money away.



Which expression shows how much money Dev has left?

$a$  is the amount of money, in pounds, that Dev gave away.

Tick one.

$10 + a$

$10 \div a$

$a - 10$

$10 - a$

$a \times 10$

---

1 mark

16.

On the grid there are three points joined by two lines.

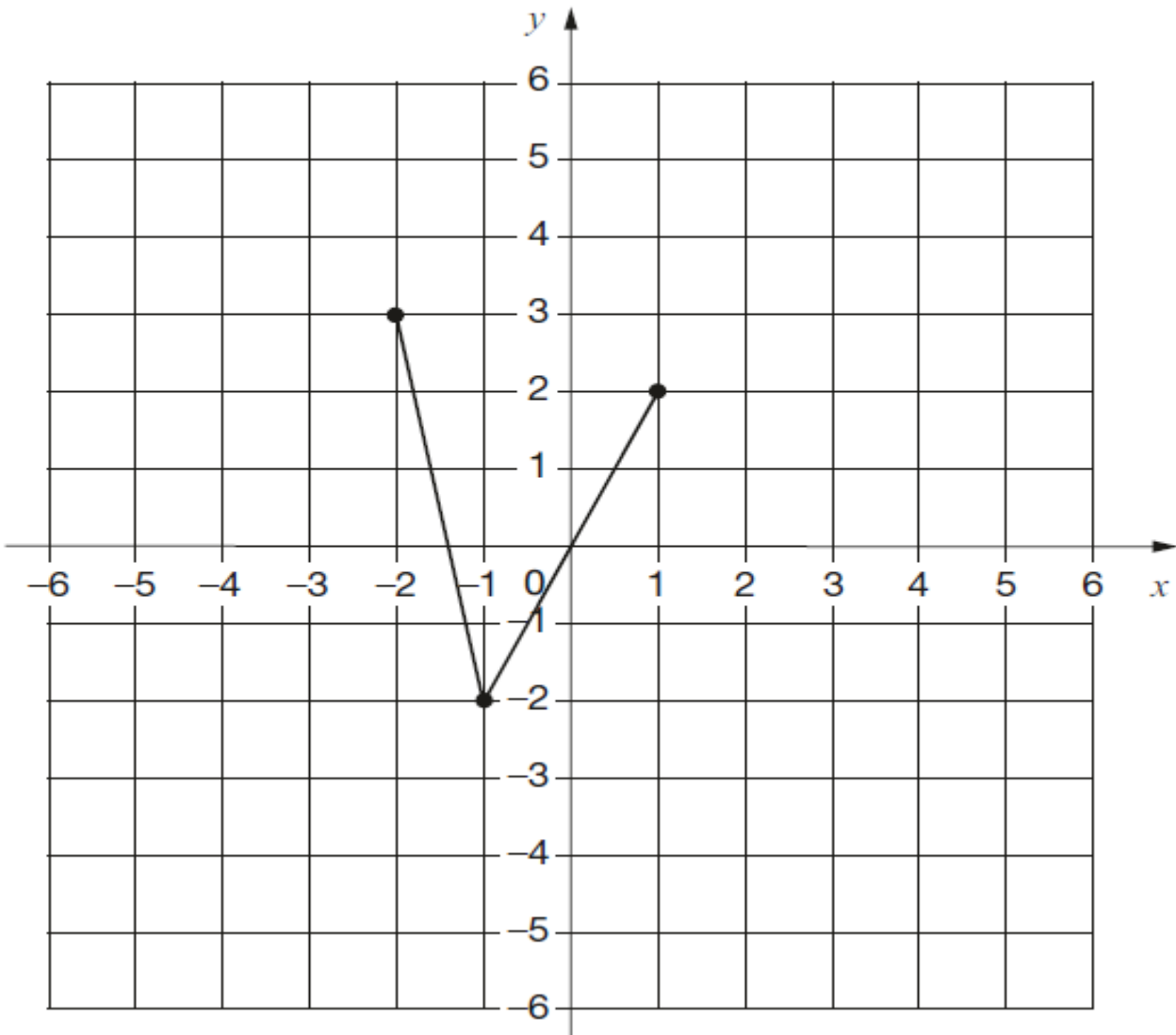

Lara plots **another point** on the grid at  $(-1, 2)$ .

She joins the points to make a quadrilateral.

Complete Lara's quadrilateral on the grid.  
Use a ruler.

Then Lara translates the quadrilateral **4 squares to the right**.

Draw the quadrilateral in its new position on the grid.

---

2 marks

17.

Here are five numbers.

~~2~~ 3 4 5 6

Write each number on the correct cards.

The number 2 has been written on the correct cards for you.

Prime numbers

2

Factors of 12

2

Factors of 15

\_\_\_\_\_

2 marks

18.

Amina's bed is 190 cm in length and 91 cm in width.

She is making a **one-tenth** scale model of the bed.

What are the length and width of Amina's model?

length =  cm

width =  cm

\_\_\_\_\_

1 mark

19.



The International Space Station orbits the Earth at a height of 250 miles.

What is the height of the International Space Station in **kilometres**?

Use 8 kilometres equals 5 miles.

\_\_\_\_\_

1 mark

20.

$$x + 2y = 20$$

$x$  and  $y$  are whole numbers **less than 10**

What could  $x$  and  $y$  be?

$x =$

$y =$

\_\_\_\_\_

1 mark

21.

Layla makes jewellery to sell at a school fair.

Each bracelet has **53** beads.

She makes **68** bracelets.

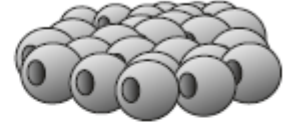

Each necklace has **105** beads.

She makes **34** necklaces.

How many beads does Layla use **altogether**?

Show  
your  
method

A large grid of 20 columns and 20 rows, used for showing the method to solve the problem. A small box labeled 'beads' is located in the bottom right corner of the grid.

beads

3 marks





23.

Six identical right-angled triangles are arranged to make a rectangle.

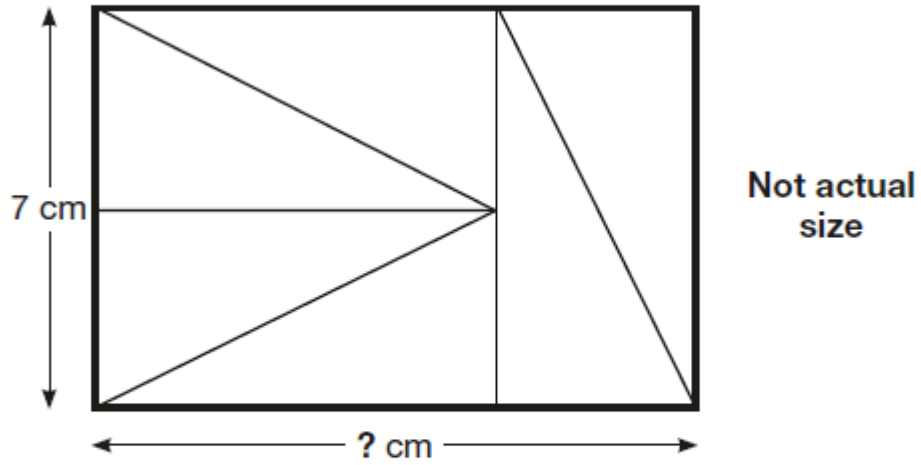

Calculate the **length** of the rectangle.

\_\_\_\_\_

1 mark

24.

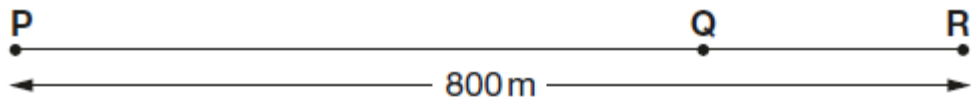

Not to scale

The distance from point **P** to point **R** is 800 metres.

The distance from point **P** to point **Q** is **4 times** the distance from point **Q** to point **R**.

Olivia says,

It is 600 metres from point **P** to point **Q**.

Explain why Olivia is **not** correct.

A large, empty, cloud-shaped box with a scalloped border, intended for the student to write their explanation.

---

1 mark